

ifm electronic



Installation Instructions
Electronic pressure sensor
for industrial applications

UK

efector500[®]
PT354x/PT954x

704676 / 00 02 / 2010

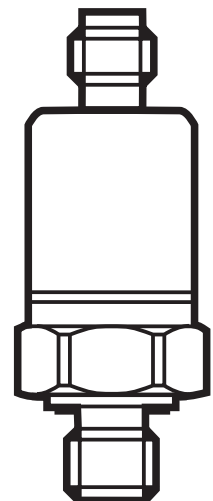

Contents

1 Safety instructions	2
2 Function and features.....	3
2.1 Applications	3
3 Installation	3
4 Electrical connection.....	4
5 Scale drawing	5
6 Technical data.....	6

1 Safety instructions

- Please read this document prior to installing the unit. Ensure that the product is suitable for your application without any restrictions.
- If the operating instructions or the technical data are not adhered to, personal injury and/or damage to property may occur.
- Please check for all applications that the product materials (see Technical data) are compatible with the media to be measured.

For the scope of validity cULus:

The device shall be supplied from an isolating transformer having a secondary Listed fuse rated either

- a) max 5 amps for voltages 0~20 Vrms (0~28.3 Vp) or
- b) 100/Vp for voltages of 20~30 Vrms (28.3~42.4 Vp).

2 Function and features

The pressure sensor detects the system pressure and converts it into an analog output signal.

- 4 ... 20 mA (PT354x) / 0 ... 10 V (PT954x)

2.1 Applications

- Type of pressure: relative pressure

Order no.	Measuring range		Permissible overload pressure		Bursting pressure	
	bar	PSI	bar	PSI	bar	PSI
PTx540	0...400	0...5 800	600	8 702	1 600	23 206
PTx541	0...250	0...3 625	400	5 800	1 000	14 504
PTx542	0...100	0...1 450	200	2 900	1 000	14 504
PTx543	0...25	0...362	60	870	600	8702
PTx544	0...10	0...145	25	362	300	4351

UK

$$\text{MPa} = \text{bar} \div 10 / \text{kPa} = \text{bar} \times 100$$



Static and dynamic overpressures exceeding the indicated overload pressure are to be avoided by taking appropriate measures.

The indicated bursting pressure must not be exceeded. Even if the bursting pressure is exceeded only for a short time, the unit can be destroyed.

NOTE: Risk of injury!

3 Installation



Before mounting and removing the sensor, make sure that no pressure is applied to the system.

- ▶ Insert the unit in a G $\frac{1}{4}$ process connection.
- ▶ Tighten firmly. Tightening torque: max. 25 Nm.

4 Electrical connection



The unit must only be connected by an electrician.

The national and international regulations for the installation of electrical equipment must be observed.

Voltage supply to EN50178, SELV, PELV..

► Disconnect power.

► Connect the unit as follows:

PT354x (4 ... 20 mA analogue)

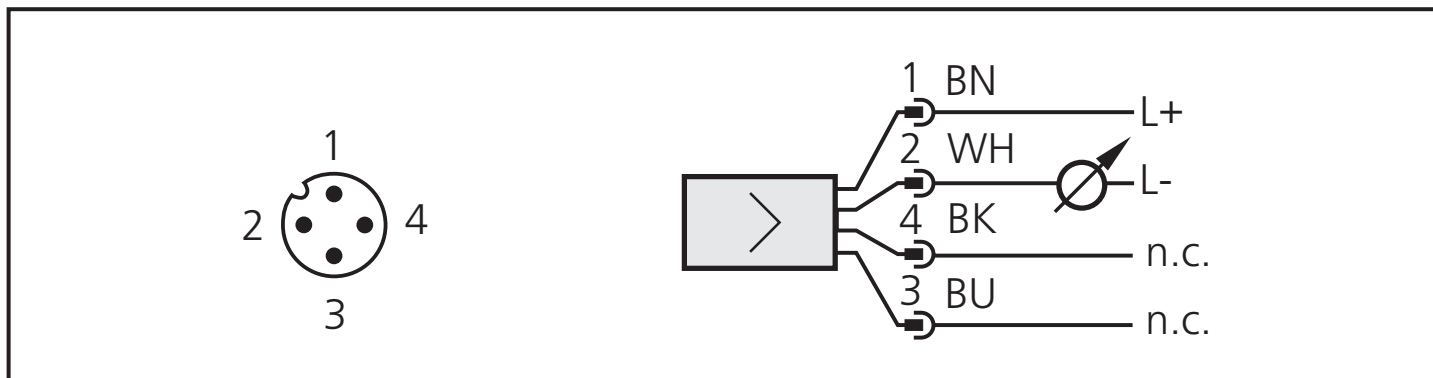

Core colours of ifm sockets:

1 = BN (brown), 2 = WH (white), 3 = BU (blue), 4 = BK (black),

n.c. = not connected.

PT954x (0 ... 10 V analogue)

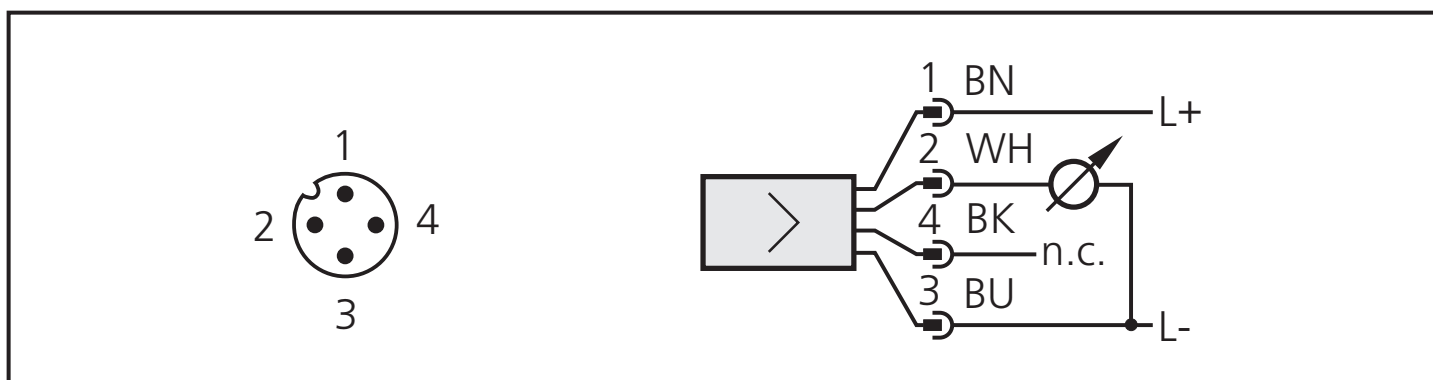

Core colours of ifm sockets:

1 = BN (brown), 2 = WH (white), 3 = BU (blue), 4 = BK (black),

n.c. = not connected.

5 Scale drawing

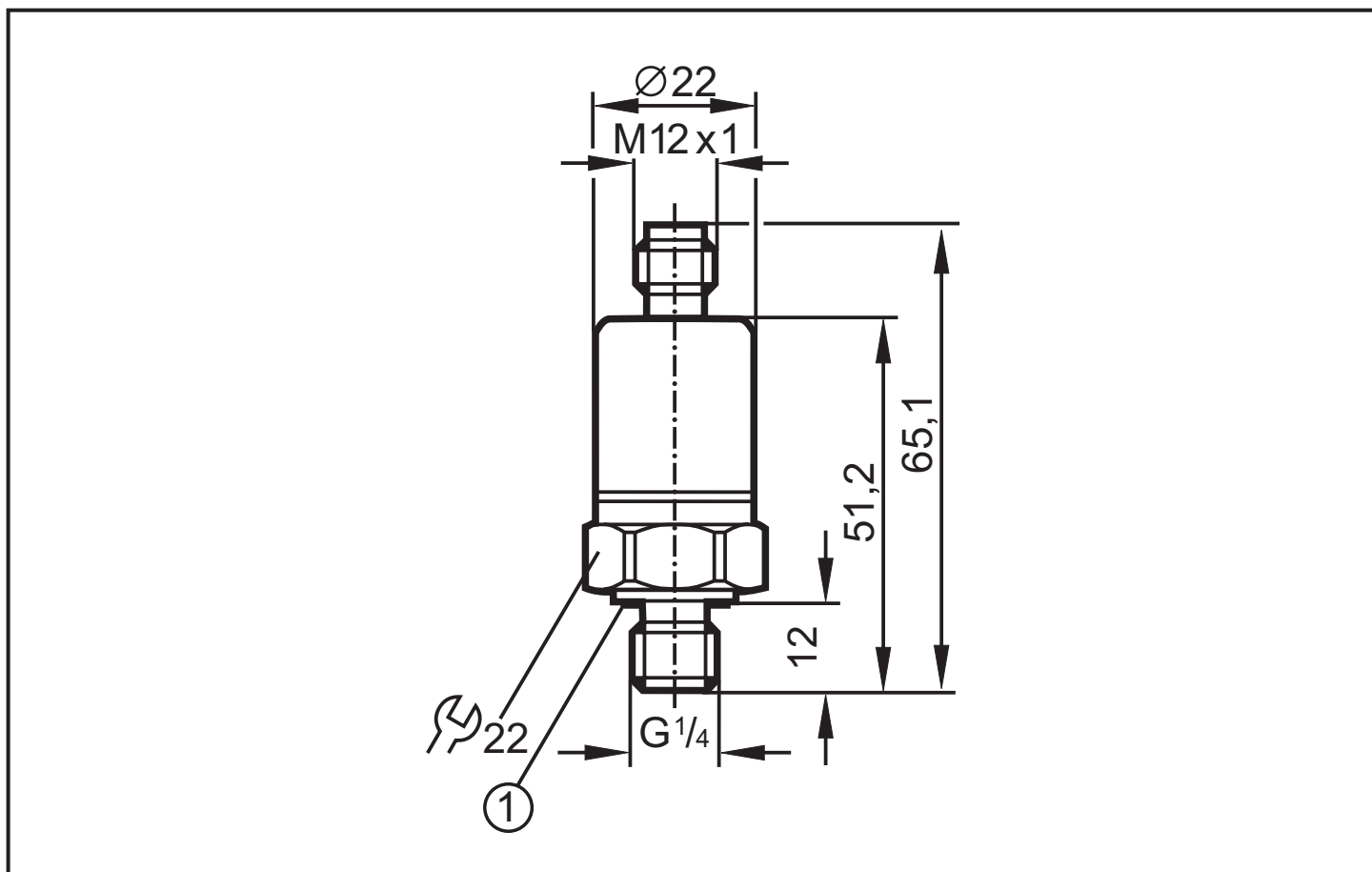

Dimensions are in millimeters
1: sealing FPM / DIN 3869-14

6 Technical data

PT354x	
Operating voltage [V].....	8.5... 36 DC
Analogue output	4 ... 20 mA
Load [Ω].....	max. (UB - 8.5) x 50; 775 at UB = 24 V
PT954x	
Operating voltage [V].....	16 ... 36 DC
Current consumption [mA].....	< 6
Analogue output	0 ... 10 V
Load [Ω].....	min. 2000
Step response time analogue output [ms].....	3
Accuracy / deviations (in % of the span)	
- Characteristics deviation *	
PTx540.....	< \pm 1.0
PTx541.....	< \pm 1.0
PTx542.....	< \pm 1.0
PTx543.....	< \pm 1.8
PTx544.....	< \pm 1.0
- Linearity.....	< \pm 0.25 (BFSL) / < \pm 0.5 (LS)
- Hysteresis.....	< \pm 0.2
- Repeatability **	< \pm 0.1
- Long-term stability in% of the span / 6 months	< \pm 0.1
Temperature coefficients (TEMPCO) (in% of the span per 10 K)	
- greatest TEMPCO of the zero point	< \pm 0.1
- greatest TEMPCO of the span	< \pm 0.1

Housing material.....	stainless steel (316S12); TROGAMID
Materials (wetted parts).....	stainless steel (316S12); sealing: FPM (Viton)
Operating temperature [°C]	-25...90
Medium temperature [°C]	-25...90
Storage temperature [°C].....	-40 ...100
Protection	IP 67 / IP69K
Protection class	III
Insulation resistance [MΩ]	> 100 (500 V DC)
Shock resistance [g]	50 (DIN / IEC 68-2-27, 11 ms)
Vibration resistance [g]	20 (DIN / IEC 68-2-6, 10 - 2000 Hz)
Min. pressure cycles.....	50 million
EMC	
EN 61000-4-2 ESD:.....	4 kV CD / 8 kV AD
EN 61000-4-3 HF HF radiated:.....	10 V/m (80...1000 MHz)
EN 61000-4-4 Burst:.....	4 kV coupling clamp
EN 61000-4-5 Surge:.....	1 kV signal for DC units
EN 61000-4-6 HF conducted:.....	10 V

UK

* incl. drift due to tightening torque, zero and span error

** with temperature fluctuations < 10 K

BFSL = Best Fit Straight Line / LS = Limit Value Setting

Technical data and further information at www.ifm.com